

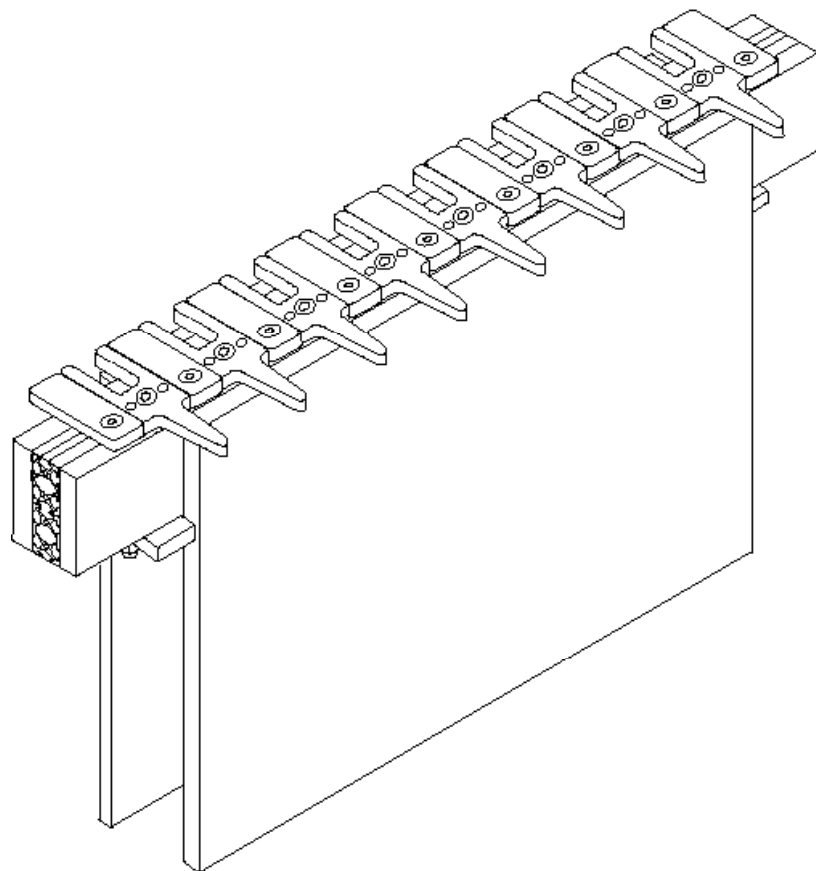

KATIE JIG®

appendix D

Blanket Chest Maker Kit



KatieJig.com

U.S. Patent #5,832,977 & 6,116,303, Proudly made in the U.S.A. 
Canadian Patent # 2,286,763

Appendix D - Blanket Chest Maker Kit

Follow the safety and general instructions for using the KATIE JIG™ System except as indicated below.

Setting Up the Blanket Chest Maker Kit (BCMK)



1. Select a method for clamping the BCMK to your workbench or work space. Two clamping options are recommended, select the one which best fits your particular situation:
 - a. Clamping option #1 requires a 2 -7/16 inch clamping arm similar to the one shown in the diagram below and will work with most woodworking vises. The length of the clamping arm will depend upon your particular vise—see the diagram below for details. The vertical support for the clamping arm must extend to the floor to give adequate support.

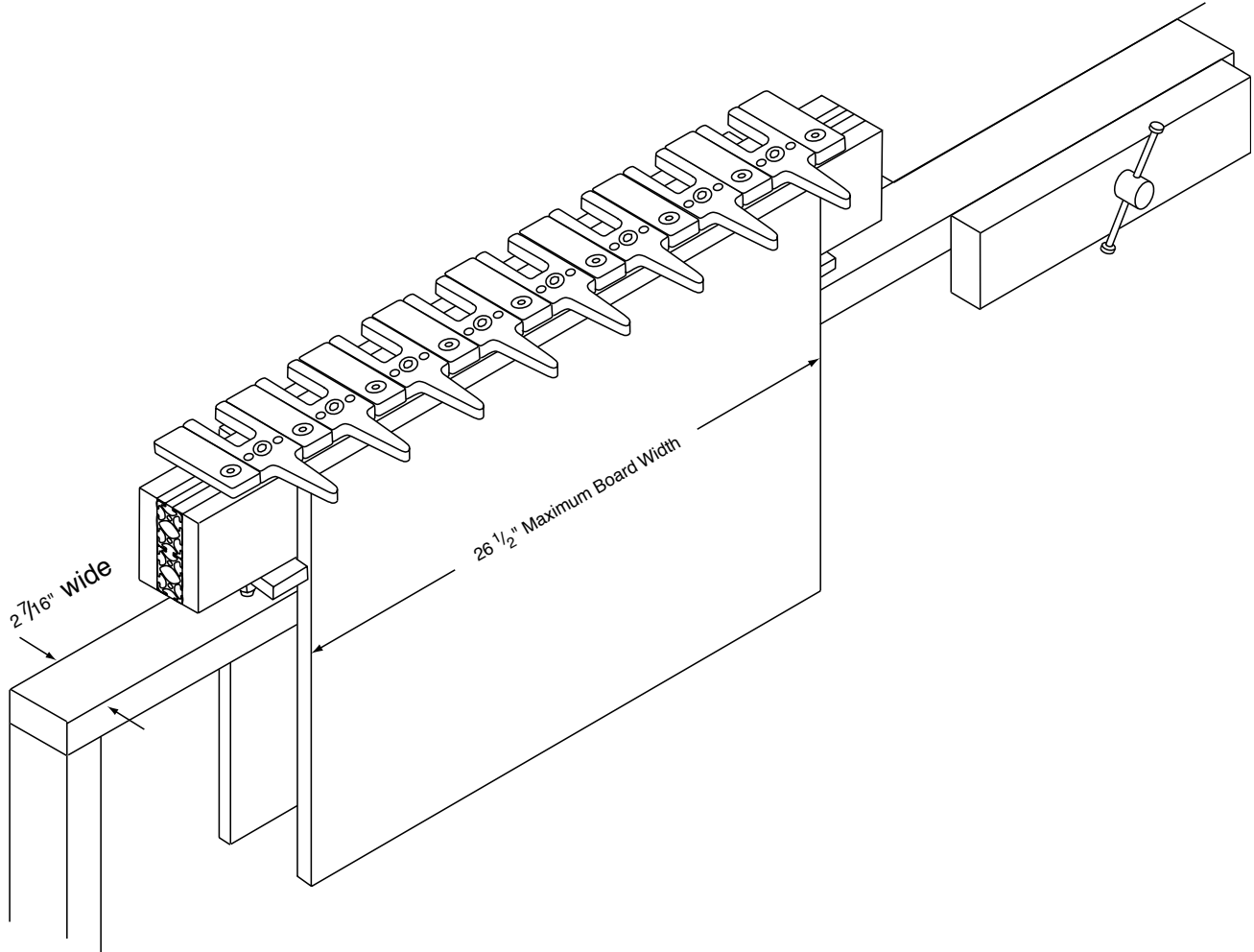

- b. Clamping option #2 requires tall saw horse with a 2-7/16 inch wide top to support the fixture. The height of the saw horse should be several inches taller than the length of your blanket chest boards.

2. Securely clamp the BCMK using a minimum of three sliding bar clamps. Two of the sliding bar clamps are used to secure the boards to the BCMK, and the third clamp is used to clamp the BCMK and boards to the clamping arm.

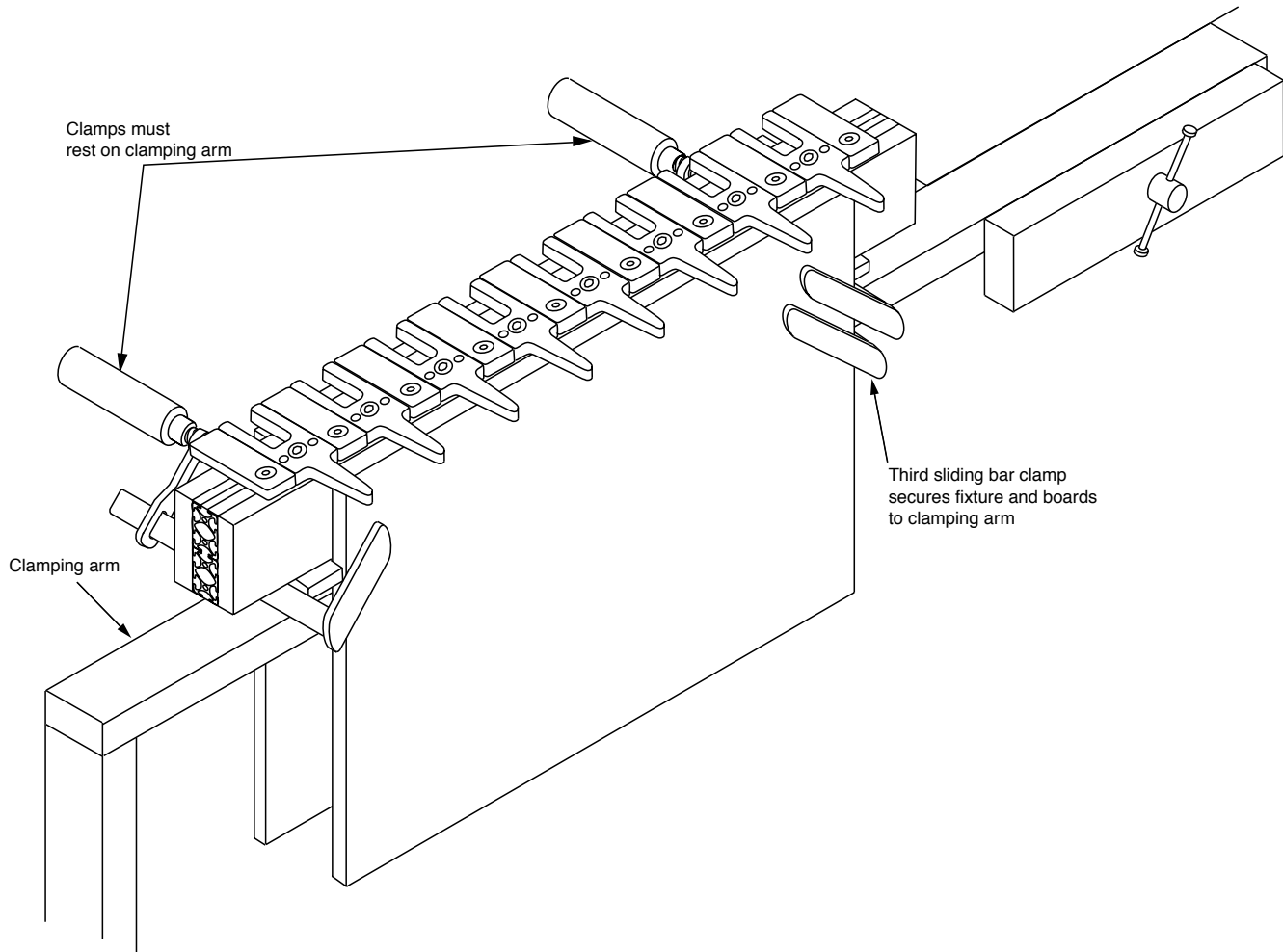

Continue with remainder of the setup and routing as described in the KATIE JIG™ System manual.

Contacting Us

If your package is missing a part or you have a broken part, please contact Machining Center, Inc. to obtain replacement parts.

Machining Center, Inc.
5719 Kopetsky Drive, Suite F
Indianapolis, IN 46217

Phone: 317-787-1965
FAX: 317-787-1973

Email: info@katiejig.com
Web: <http://www.katiejig.com/>